

ON 3MG

NO	DESCRIPTION	MAT'L	Q'TY	UNIT / TOTAL		REMARKS
				WEIGHT (Kg)		

SPECIFICATION	
MODEL	SHW-H-0015
RATED LOAD	1500 kg
LIFTING	60 m
REDUCTION RATIO	1 / 50.29
LIFTING SPEED	18 m/min
CONTINUOUS PRESSURE	210 Kg/cm ²
WIRE ROPE	ø16
LIFTING BRAKE	DISC BRAKE

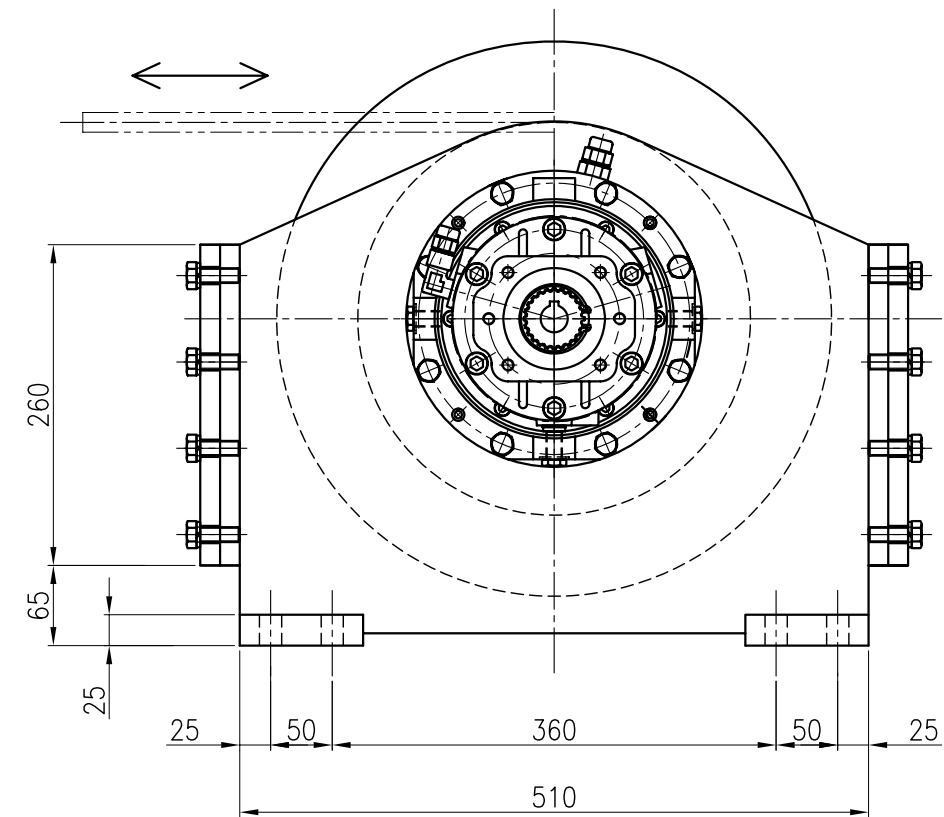
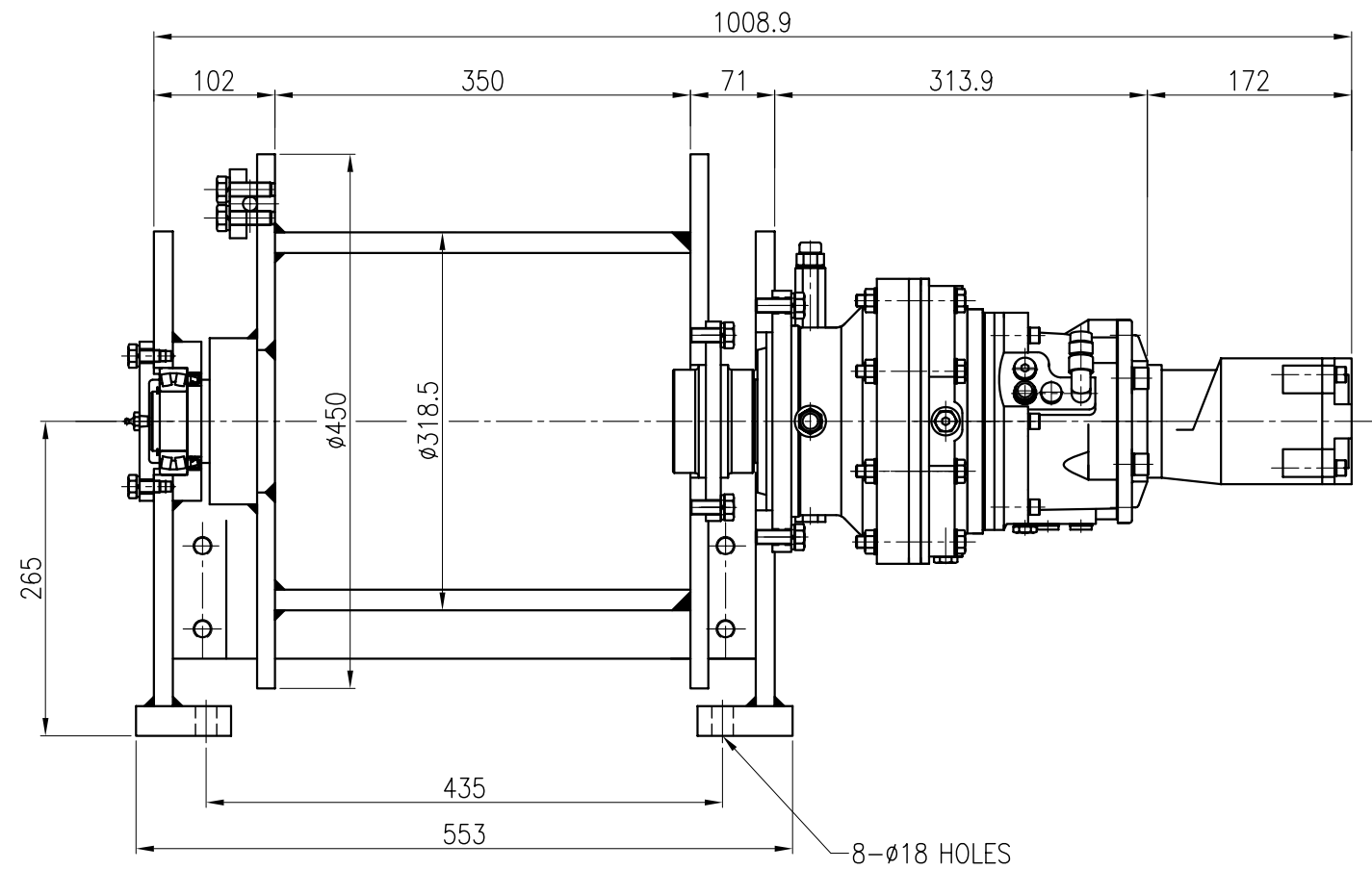

SURFACE	Hmax(u)	3S	6S	12S	25S	50S

NO.	DATE	REVISIONS & DESCRIPTION	Drawn	Checked	Reviewed	Approved

		SCALE	N/S	DATE	-			
PROJECT	-	DIM.	mm	PROJECTION				
TITLE	HYDRAULICS WINCH (1500kg)		Customer	-				
Division	Checked	Reviewed	Approved	Division	Drawn	Checked	Reviewed	Approved
USER	Signature	Date	Signature	KHS	Date	Date	Date	Date
DWG No.	A - SHM - HW015 - 01		Cod No.					

